

Transformer Specifications	
PRIMARY VOLTAGE(S)	208/230/460
SECONDARY VOLTAGE(S)	115
RATED V.A.	75
RATED FREQUENCY	50/60
INSULATION CLASS	105
AGENCY APPROVALS	UL,CUL
ESTIMATED WEIGHT	2.5 LBS

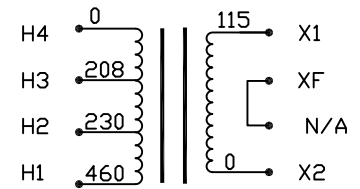
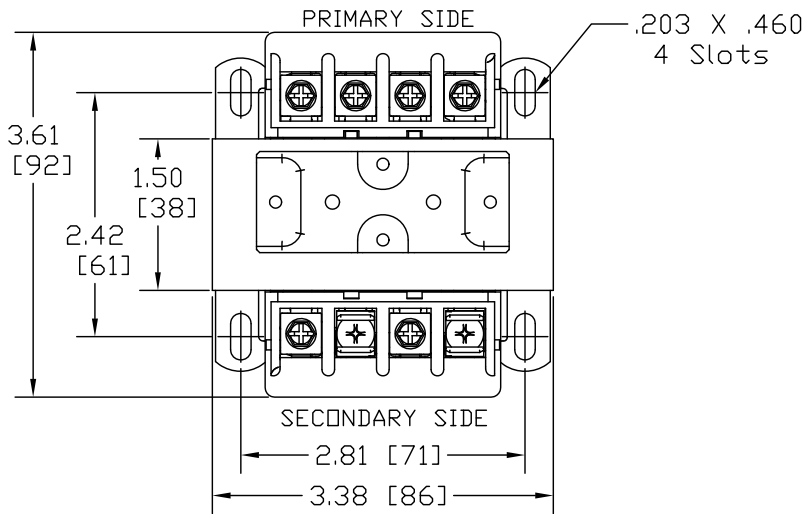

INTERNALLY JUMPERED TO FUSE TERMINAL  
CONNECTION DIAGRAM

NOTES:

1. ALL MEASUREMENTS IN INCHES (MM)
2. TERMINAL SCREWS ARE COMBO #8-32 PHIL-SLOT-1/4" HEX WITH SEMS WASHER.
3. SECONDARY FUSE CLIP ACCOMMODATES ONE 13/32" X 1-1/2" MIDGET FUSE.

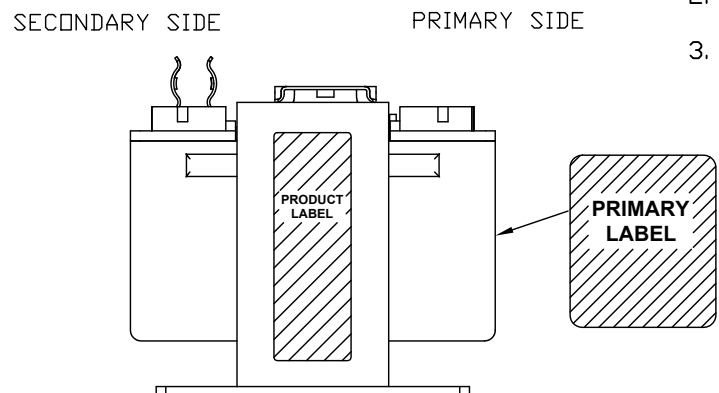
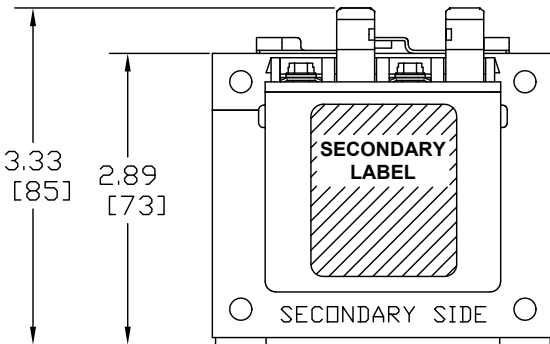

PACKAGED ACCESSORIES	
1	
-	-

**MICRON** INDUSTRIES CORPORATION  
 1211 V. 22nd STREET, Suite 200, DAK BROOK, ILL.  
 Tel: (630)664-4660, (630)516-1822 Fax: (630)516-1820  
 www.MicronPower.com

DATE	10/29/07	DRAWN	J.G.V.	CHECKED		APPROVED	
RELEASE DATE		CUSTOMER		PART NO.			
MICRON		B075MBT13XKA3					
PART NO.		B075MBT13XKB3					
SIZE	C	SCALE	NONE	B075MBT13XK			

A	13 CONSTRUCTION	AN00XXXX	XX	XXXX
ECL	REVISIONS		BY	DATE