

Transformer Specifications	
PRIMARY VOLTAGE(S)	208/277
SECONDARY VOLTAGE(S)	120
RATED V.A.	100
RATED FREQUENCY	50/60
INSULATION CLASS	105
AGENCY APPROVALS	UL, CUL
ESTIMATED WEIGHT	4.2 LBS

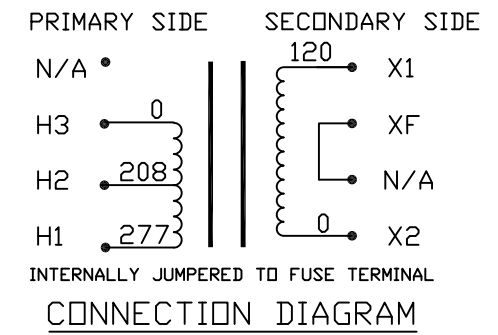

- NOTES:
1. ALL MEASUREMENTS IN INCHES (MM)
  2. TERMINAL SCREWS ARE COMBO #8-32 PHIL-SLOT-1/4" HEX WITH SEMS WASHER.
  3. 2 POLE, CLASS "CC" PRIMARY FUSE BLOCK, ACCOMMODATES TWO 13/32" X 1-1/2" CLASS "CC" FUSES.
  4. SECONDARY FUSE CLIP ACCOMMODATES ONE 13/32" X 1-1/2" MIDGET FUSE.

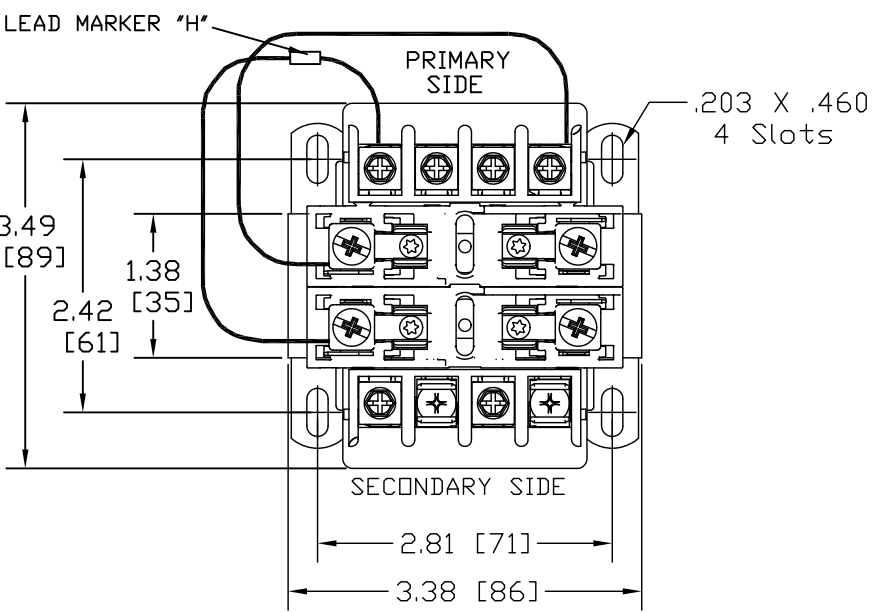
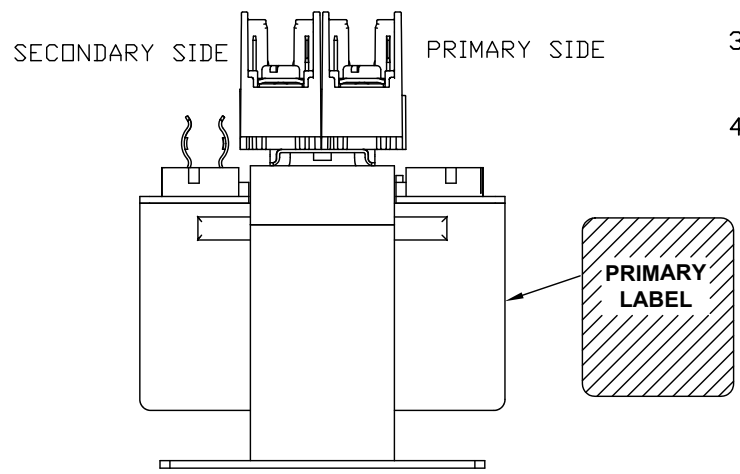
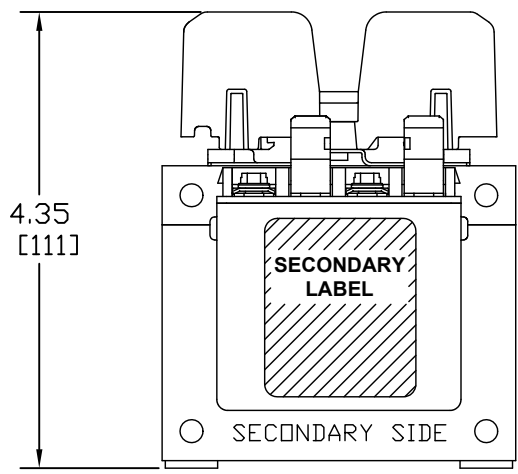

PACKAGED ACCESSORIES			
1			
-	-		
<b>MICRON INDUSTRIES CORPORATION</b> 1211 W. 22nd STREET, Suite 200, OAK BROOK, ILL. Tel. (800)664-4660, (630)516-1222 Fax (630)516-1820 www.MicronPower.com			
DATE	7/10/09	DRAWN	J.G.V.
CHECKED		APPROVED	
RELEASED		CUSTOMER PART NO.	
MICRON PART NO.	B100MQ15RKA3 B100MQ15RKB3		
SIZE	B	SCALE	B100MQ15RK

A	I3 CONSTRUCTION	AN00XXXX	XX	XXXX
ECL	REVISIONS		BY	DATE